



CD Receiver with Codem III-US Tuner

Récepteur/Lecteur CD avec Syntoniseur Codem III-US

Receptor/Reproductor de CD con Sintonizador Codem III-US

CD Receptor com Sintonizador Codem III-US

● BLAUPUNKT.
Bosch Group

FCC Warning

The equipment has been tested and found to comply with the limits for a Class B device, pursuant to Part 15 of the FCC Rules. These limits are designed to provide reasonable protection against harmful interference in a residential installation. This equipment generates, uses, and can radiate radio frequency energy, and, if not installed and used in accordance with instructions, may cause harmful interference with radio communications. However, there is no guarantee that radio interference will not occur in particular installation. If this equipment does cause harmful interference to radio or television reception, which can be determined by turning the equipment off and on, the user is encouraged to contact the dealer or an experienced Radio/TV technician for help.

You are cautioned that any changes or modifications not expressly approved in this manual could void your authority to operate this equipment.

CAUTION

- The use of optical instruments with this product will increase eye hazard.
- Because the invisible laser beam in this compact disc player is harmful to the eyes, do not attempt to disassemble this cabinet. Refer servicing to qualified personnel only.

SAFETY CERTIFICATION

This Compact Disc Player is made and tested to meet exacting safety standards. It meets FCC requirements and complies with safety performance standards of the US Department of Health and Human Services.

Owner's Record

The model and warranty numbers are located on the top of the unit. Record the warranty (serial) number in the space provided below. Refer to these numbers whenever you call upon your Blaupunkt dealer regarding this product.

Warranty Number _____

Attach Sales Receipt Here

Table of Contents

English

FCC Warning	2
Owner's Record	2
Features	4
Precautions	4
Detachable Face	5
Electrical Connections and Installation	6
Installation	8
Maintenance	10
Specifications	11
Location of Controls	12
Instructions—General Operation	12
Audio Operation	13
Radio Operation	14
CD Player Operation	15
Auxiliary Input Jack	16
Troubleshooting Guide	16

Français

Avertissement de la FCC	18
Archive du Propriétaire	18
Caractéristiques	19
Précautions à Prendre	19
Face Avant Amovible	20
Raccordements Électriques et Installation	21
Installation	23
Entretien	25
Spécifications	26
Emplacements des Commandes	27
Mode d'Emploi/Fonctionnement Général	27
Fonctionnement de l'Audio	29
Fonctionnement de la Radio	29
Fonctionnement du Lecteur de CD	31
Prise Auxiliaire	32
Guide de Dépannage	32

Español

Advertencias FCC	34
Registro del Propietario	34
Características	35
Precauciones	35
Panel Frontal Desmontable (Carátula)	36
Conexiones Eléctricas e Instalación	37
Instalación	39
Mantenimiento	41
Especificaciones	42
Ubicación de los Controles	43
Instrucciones de Funcionamiento	43
Funcionamiento de Audio	45
Funcionamiento de la Radio	45
Funcionamiento del CD	47
Toma de Entrada Auxiliar	48
Guía para la Solución de Problemas	48

Portuguese

Aviso da FCC	50
Registro do Proprietário	50
Características	51
Precauções	51
Painel Removível	52
Conexões Eléctricas e Instalação	53
Instalação	55
Manutenção	57
Especificações	58
Posição dos Controles	59
Instruções-Funcionamento Geral	59
Funcionamento do Audio	61
Funcionamento do Rádio	62
Funcionamento do CD	63
Tomada para Entrada Auxiliar	64
Guia para Solução de Problemas	65

Features

Congratulations on your purchase of this Blaupunkt CD Receiver. Its Codem III-US FM/AM Tuner and 3-Beam Laser/Anti-Vibration & Anti-Shock CD Player mechanism provide the ultimate in sound reproduction. Its high-power amplifier and 4-Channel preamp output provide you with tremendous system configuration flexibility. Its auxiliary input jack lets you easily incorporate portable audio equipment, such as a cassette or DAT player, into your car's sound system.

- Codem III-US Tuner Features:
 - Multipath Management
 - ASU Electrical Impulse Noise Reduction
 - Superior AM Frequency Response
 - 15 FM/5 AM Presets, Including 5 FM & 5 AM Travel Store Presets
 - Station Scan
 - Local/Distant Seek & Manual Tuning
- CD Player Features
 - Track Up/Down
 - Scan, Mix, Repeat
 - Cue/Review & Pause/Play
 - CD IN Indicator
 - Last Position Memory
 - 3-Beam Laser Pick-Up
 - 1 Bit/8 Times Oversampling Digital Filter
 - Silicone-Oil Dampened Anti-Vibration and Anti-Shock CD Mechanism
- Audio Features:
 - 30 Watts x 4 Channel Integrated Amplifier
 - Dual-Level Fader
 - Over 3 Volts of Distortion-Free Preamp Output
 - 4-Channel, Low Impedance (100 Ω) Preamplifier
 - 2-Channel RCA Preamp Output Harness Included
 - Bass, Treble, Balance, Fader Controls
 - Adjustable Maximum Turn-On Volume
 - Loudness Button
 - Mute Button
 - Auxiliary Input
- Other Features:
 - Partially Detachable Face
 - Green Illumination
 - Display Priority Control
 - Temporary Display Change Control
 - Clock/Ignition-Off Clock Recall
 - 180 x 50 x 155 mm (7 x 2 x 6 1/8 in.) DIN/ISO Chassis
 - Detachable Wire Harness
 - Snap-In DIN Sleeve & Mounting Hardware
 - Side-Bracket Compatible

Your unit's detachable front faceplate makes the unit useless to would-be thieves.

Designed, Engineered and Manufactured By Blaupunkt.

Traffic Safety and Precautions

- Do not adjust your unit in difficult driving conditions that demand your full attention.
- As the driver of a motor vehicle, it is your responsibility to pay attention to the traffic situation at all times. Never use your unit in a way that could distract you.
- Always make sure that you are still able to hear any warning signals coming from outside of the vehicle, such as police or fire engine sirens, so that you can react accordingly.
- If your vehicle was parked in direct sunlight resulting in a considerable rise in temperature inside the vehicle, allow the unit to cool off before operating your unit.
- The use of optical instruments with this product will increase eye hazard.
- Because the invisible laser beam in this compact disc player is harmful to the eyes, do not attempt to disassemble this cabinet. Refer servicing to qualified personnel only.
- You are cautioned that any changes or modifications not expressly approved in this manual could void your warranty.
- Before any jump startings, disconnect all wire harnesses from rear of unit.
- Car Wash precaution - If you have a motorized antenna, make sure to turn off the unit - not just the tuner - so that the antenna is lowered and antenna damage is prevented.

Detachable Face

Detaching & Attaching the Face:

The face of this unit can be detached and taken with you to prevent it from being stolen.

Detaching the Face:

Press the REL (Release) Button and detach the face by gently pulling it off as illustrated.

Note: Do not pull it straight out from the chassis. Be sure not to drop the face when detaching it from the chassis.

Attaching the Face:

Apply the right hand side of the face to the chassis by sliding (part B) of the face to (part A) at the front of the chassis. Gently push the left side of the face against the front of the chassis until it snaps into place.

Note: Make sure that the face is inserted right side up. Do not press against the display window. Do not press hard against the face when attaching it to the chassis, it may be easily attached with gentle pressure. Do not expose the face to direct sunlight, heat sources such as hot air ducts or leave it in a humid place. Never leave it on the dash board of a vehicle parked in direct sunlight, where there may be a considerable rise in temperature inside the vehicle.

Affixing Faceplate For Retail Display:

The faceplate can be affixed to the unit's chassis, which is desirable for a retail display, for example.

To affix the faceplate:

Insert the black bolt into the hole at the left front of the top of the radio. See* below.

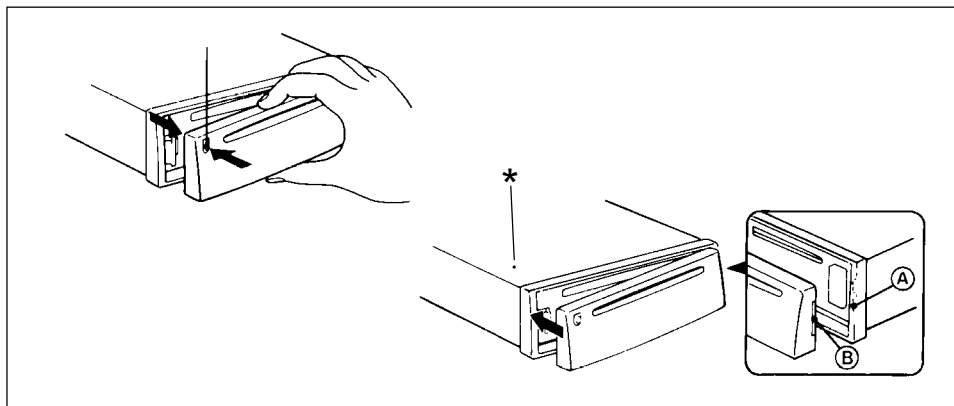

Electrical Connections and Installation

!To avoid the aggravation of costly mistakes and serious damage that could make you feel this way, please carefully read all of the instructions before you begin. Carefully follow all instructions. You'll be glad you did!

GENERAL RECOMMENDATIONS

- If you're not confident that you can install the unit correctly, have it installed by a qualified Blaupunkt installation technician.
- Use this unit only with negative ground 12 Volt (11-16 Volt) direct current (DC).
- Be sure to detach the faceplate before you start to connect or install the unit.
- Don't assume that a seemingly matching wire harness in the vehicle has leads that match the leads of the unit's wire harness.
- We recommend making and testing all electrical connections before installing the unit. Connect the leads (wires) according to instructions and diagram below.

ELECTRICAL CONNECTION INSTRUCTIONS

1. Disconnect the vehicle battery's negative terminal before making connections.
2. Connect the speakers and/or external amplifiers (if you have any) following the guidelines in the SPEAKER CONNECTION section below.
3. Connect the blue (trigger output) lead to the amplifier's trigger input terminal and/or antenna motor trigger input terminal (if you have either or both of these items). The combined total amperage required for triggering the antenna motor and/or amplifier must not exceed 300 mA. DO NOT connect the blue lead to the antenna's and/or amplifier's power supply input.
4. Connect the black (power ground) lead to a grounded metal part on the vehicle. We recommend grounding all audio system black ground leads (head unit, external amplifier, etc.) to a common grounding point, preferably a non-painted surface under the instrument panel.
5. Connect the yellow (constant power) input lead to a source of constant battery power, preferably a terminal to an appropriate slot in the fuse box.
6. Connect the red (turn-on power) input lead only after the other leads are connected. Be sure to connect the red lead to a positive (+) 12 Volt power terminal that is energized only when the ignition key is set to the on position or accessory position.
7. Cover the ends of any unused leads with electrical tape. This will prevent them from touching the vehicle or each other and causing a short-circuit and damage to the radio or vehicle.
8. Reconnect the vehicle's battery.
9. Verify that no fuses have blown.
10. Plug the harness into the unit.
11. Attach the faceplate and test the unit.

Once the connections have been successfully made, you can begin to mount the unit.

SPEAKER CONNECTIONS

The unit's Dual-Level Fader allows you to fade between the front and the rear channels using either the front and/or rear speaker leads and/or the rear preamp outputs, providing you tremendous flexibility in configuring your speaker arrangement:

- You can connect a speaker (regular, co-axial or tri-axial speakers or component speaker system, all hereafter referred to simply as "speaker") to each of the unit's four pairs of speaker leads.
- You can connect the 2 RCA preamp outputs to multiple external amplifiers and power multiple speakers or speaker systems through the amplifiers. (Blaupunkt amplifiers and speakers available separately). To add front preamp output, purchase Blaupunkt part 8634494218 which is included in the CDC-A05 and CDC-A071 changer's harnesses.
- You can use either or both of these two methods.

Connecting the Speaker Leads

To prevent short circuits or serious damage to the unit and/or speakers:

- Connect the speaker leads only as indicated in the wiring diagram. Disconnect the vehicle battery's negative terminal before making connections.

- Only use speakers that have impedance ratings of 4 ohms or higher and have power-handling capabilities greater than the receiver's stated power level.
- The unit's internal amplifier is designed to handle a 4-ohm load on each pair of speaker leads.
- DON'T connect two speakers to a single pair of speaker leads ("in parallel") unless both speakers each have at least 8 ohms impedance.
- DON'T connect the left and right speaker leads to each other or to the same speakers.
- DON'T connect the front and rear speaker leads to each other or to the same speakers.
- DON'T connect the negative speaker leads to each other.
- DON'T connect the positive speaker leads to each other.
- DON'T connect any active speakers (with built-in amplifiers) to the speaker leads unless their owner's manuals specifically state that this is O.K.
- Cover the ends of any unused leads with electrical tape. This will prevent them from touching the vehicle or each other and causing a short-circuit and damage to the receiver or vehicle.

Connecting the Pre-Amp Outputs to External Amplifier(s)

To prevent short circuits or serious damage to the receiver, amplifier, and/or speakers:

- Follow the amplifier's instructions on how to connect the unit's preamp outputs to the amplifier(s)

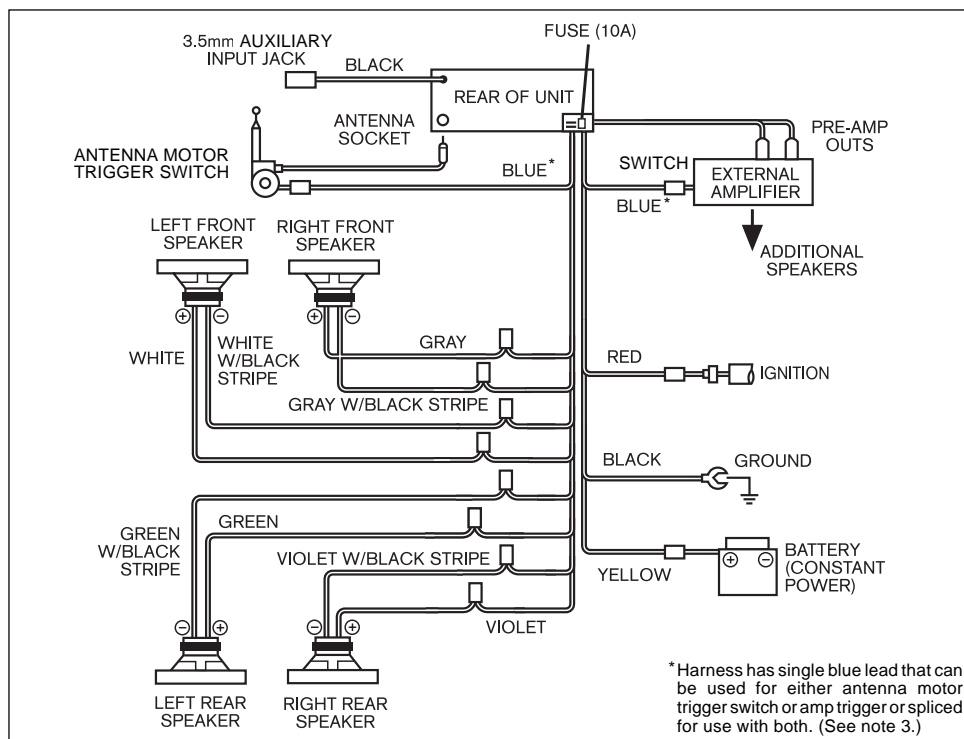

and connect the speaker(s) directly to the amplifier.

Installation

Recommendations

- Carefully choose the mounting location so that the unit won't interfere with normal driving.
- Avoid mounting locations where the unit would be subject to high temperatures, such as from direct sunlight or hot air from the heater, or where it would be subject to dust, dirt or excessive vibration.
- The illustration below shows a typical installation, however, you may need to adjust the installation, depending on the unit. If you have questions or need additional installation hardware, consult your Blaupunkt dealer.
- Make sure the unit is firmly anchored (preferably at both front and back) and does not vibrate.

Mounting Hardware

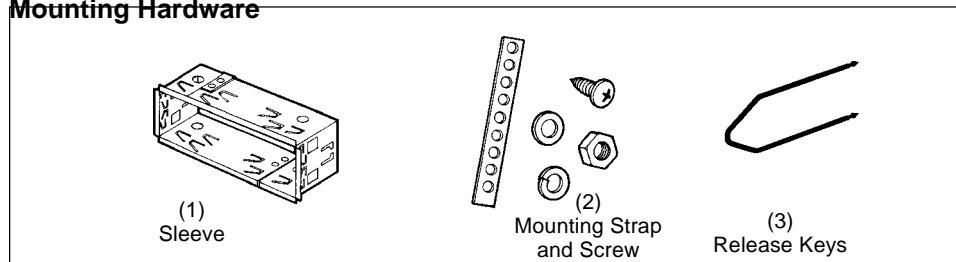

Mounting The Unit in Most Dashboards

- 1 Install the Sleeve (1) in the dashboard.
- 2 Select and bend the appropriate tabs to hold the sleeve firmly in place.
- 3 A. Attach the Mounting Strap (2) to the underside of the dashboard, using screw.
B. Attach the back of the unit to the mounting strap using the support stem bolt and hardware.

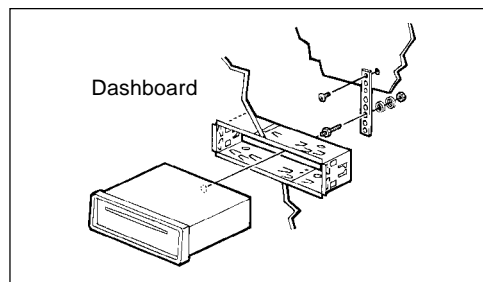
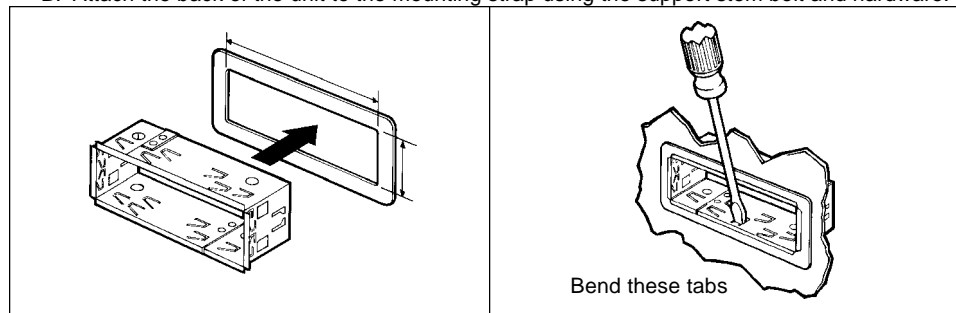

Mounting the Unit in a Japanese Car

You may have difficulty mounting this unit in some Japanese cars that have ISO mounting features (side-bracket mounting systems).

In this case, consult your Blaupunkt dealer.

- 1 Run a blade along the slits on the back of the front trim ring, unscrew the two side screws, and separate it from the unit. Save the trim ring and related hardware in case you ever want to install the unit in another vehicle.

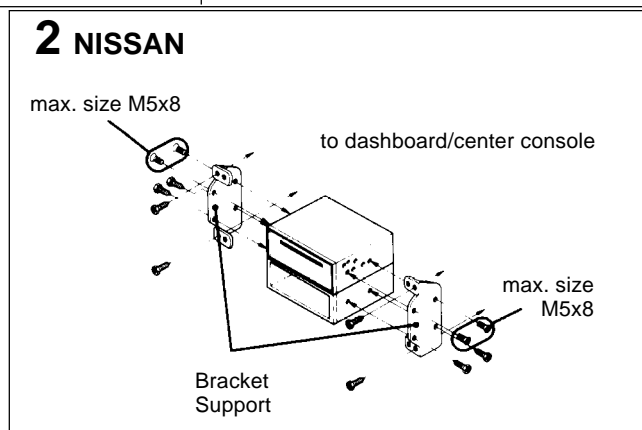
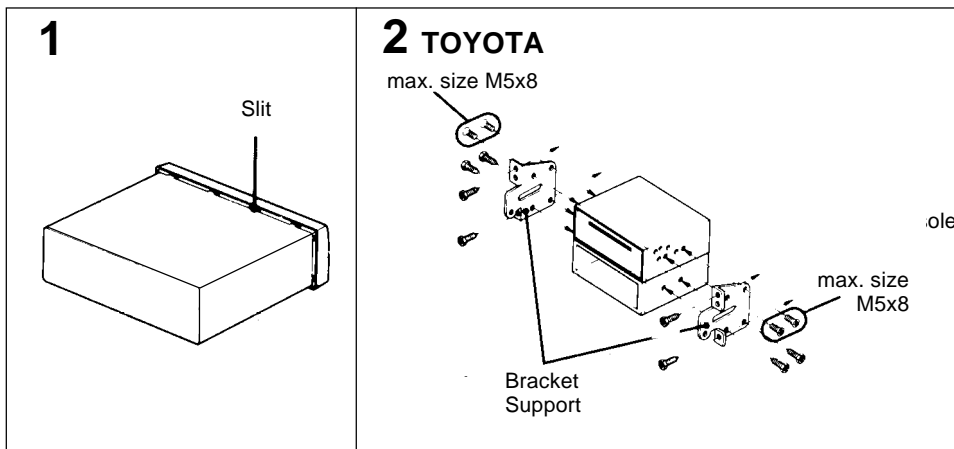

- 2 Use the vehicle's own mounting hardware to attach the unit.

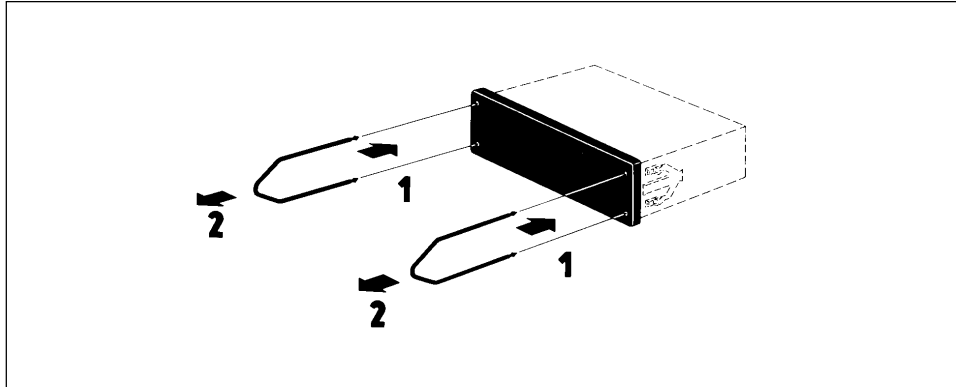

Maintenance

Removing the Unit

Use the Release Keys as shown below. Keep them in a safe place in case you need them in the future.

Fuse Replacement

When replacing the fuse, be sure to use one with the correct amperage, which will be stated on the fuse case. Never use a fuse that has a stated amperage exceeding the one supplied for this unit, as this could cause malfunction and serious damage to the unit.

Specifications

Audio Power Specifications

Power Output and Total Harmonic Distortion: 13 watts per channel minimum continuous average output into 4 ohms, 4 channels driven, from 30-15,000 Hz with no more than 1% total harmonic distortion.

Other Specifications

Tuner

FM

Tuning Range:	87.5 - 107.9 MHz
Intermediate Frequency:	10.7 MHz
FM Mono Sensitivity:	13 dBf
Seek lo sensitivity:	51 dBf
Seek sensitivity	31 dBf
Selectivity:	80 dB at 400kHz
Signal-to-Noise Ratio:	65 dB (stereo), 70 dB (mono)
Harmonic distortion at 1 kHz:	0.7% (stereo), 0.5% (mono)
Separation:	30 dB
Frequency Response:	30-15,000 Hz \pm 3 dB

AM

Tuning Range:	530 - 1,710 kHz
Seek lo sensitivity	50 dB μ V
Seek sensitivity:	25 dB μ V
Intermediate Frequency:	450 kHz
Signal-to-Noise Ratio:	50 dB
Frequency Response:	30-5,000 Hz \pm 3dB

Audio

Speaker Impedance:	4-8 ohms
Maximum Amp Power:	4 X 30 Watts (at 4 ohms)
RMS Power:	4 X 13 Watts (at 4 ohms) <1% THD
Bass Control:	\pm 10 dB @ 100 Hz
Treble Control:	\pm 10 dB @ 10 kHz
Loud:	+ 8 dB @ 60 Hz & + 2 dB @ 8 kHz
Preamp Output:	4-Channel, Low-Impedance (100 Ω) Preamplifier Over 3 Volts of Distortion-Free Preamp Output

CD Player

Signal-to-Noise Ratio:	90 dB
Dynamic Range:	90 dB
Frequency Response:	5-20,000 Hz \pm 3 dB
Harmonic Distortion:	.01%

General

Dimensions (w/o projecting parts/controls):	180 x 52 x 155 mm, 7 x 3 x 6 ¹ / ₈ in.
Mass:	Approx. 1.4 kg (3.0 lb.)
Power Requirement (neg. grd.):	12 V DC car battery (11-16 V DC allowable)
Operating Temperature:	15°F to 120°F, -10°C to 50°C
Supplied Accessories:	<ul style="list-style-type: none">• Unit• Faceplate• Wire Harness, including 2-Channel RCA Preamp Output Harness• DIN Sleeve• Mounting Hardware• Owner's Manual in English, French, Spanish and Portuguese
Optional Accessories:	<ul style="list-style-type: none">• 4-Channel Preamp Output Harness (Part No. 8634494218)

Design and specifications subject to change without notice.

Location of Controls

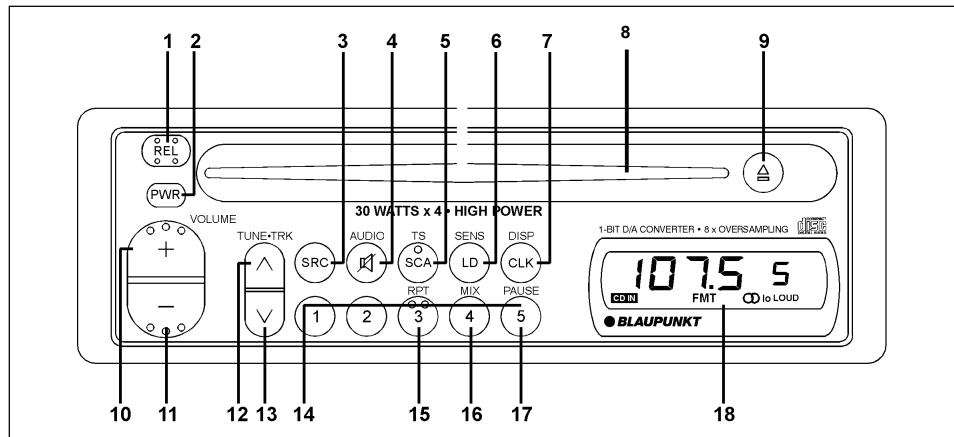

- | | |
|---|------------------------|
| 1. REL (Release) Button | 12. ^ Button |
| 2. PWR (Power) Button | Seek and Manual Tuning |
| 3. Source (and Radio Band) Select | Track Up |
| 4. Mute/Audio Button | Audible CD Cue |
| 5. SCA (Scan) TS (Travel Store) | Clock Hours |
| 6. LD (Loudness)/ SENS (Tuning Sensitivity) | 13. v Button |
| 7. CLK/Display Change | Seek and Manual Tuning |
| 8. Disc Insertion Slot | Track Down |
| 9. CD Eject | Audible CD Review |
| 10. + Button | Clock Minutes |
| Volume + | 14. FM/AM Presets |
| Bass + | 15. CD RPT |
| Treble + | 16. CD MIX |
| Balance Left | 17. CD Pause |
| Fade to Front | 18. Display |
| 11. - Button | |
| Volume - | |
| Bass - | |
| Treble - | |
| Balance Right | |
| Fade to Rear | |

Instructions — General Operation

See Traffic Safety & Precautions on page 4.

"Press" means a momentary press of less than 1/2 second. All presses requiring more than 1/2 second are followed by beep.

"Time Out" When additional button presses are anticipated to complete a procedure, the unit will automatically exit the procedure after 4 seconds of inactivity.

Ignition-Off Clock Recall

Any button press while ignition off displays time for about 8 seconds.

Ignition-On

Unit lights up and clock is displayed.

Release for Detachable Faceplate

Push REL to detach face. Already-inserted CD remains in unit. Current settings and source mode are stored. If power was not switched off before face removed, unit will automatically power-on when face is reattached.

Power (PWR) On/Off

When ignition on, press PWR or insert a disc to turn unit on. Last-used source becomes active, unless unit is turned on by inserting disc, in which case CD player becomes active.

Power Off

Press PWR to turn unit off. Unit stores current settings for source, station or track, etc. Antenna/amplifier trigger wire shuts off voltage. (If faceplate still attached, display switches to clock.)

Setting the Clock

Turn the unit on. Press the CLK Button for four seconds until the clock starts blinking. (The display will change after two seconds. Ignore this and continue to hold for two more seconds.) Once the clock starts blinking, Press the \wedge to set the hour, and press the \vee Button to set the minutes. (To change the minute indicator to the nearest hour (:00), you can press the MUTE Button. Press the CLK Button again to activate the clock.

Changing the Information Displayed

You can temporarily change the information shown in your unit's display. You can also select which information has "display priority" and is shown in the display except for moments when adjustments are made.

- To change the display priority, press the CLK Button for two seconds. The display priority changes. The display priority choices are clock or Radio Frequency and Elapsed Play Time / Track Number.
- To change the display temporarily, press and release the CLK Button to access the desired information.* After five seconds, the display changes back to the priority information.

Source (SRC)

Use SRC to select source - AMT, FM1, FM2, FMT or CD (if already inserted), and/or auxiliary input (even if no input on aux in line).

Audio Operation

Volume Control Buttons (+/-)

Press + and - to increase/decrease volume from 0 to 63, in increments of 1.25 dB/step. Volume control is accessible from all modes except Bass, Treble, Balance and Fade modes.

Adjustable Maximum Turn-On Volume

First adjust the volume to the (maximum) volume level desired when the unit is turned on. Press and hold the PWR Button for more than two seconds. The unit turns off and the turn-on volume level is memorized. When the unit is turned on, the volume will be at the memorized level, even if the unit was turned off while the volume was at a higher level. However, if the volume is turned off when the volume level is lower than the stored Turn-On volume level, the volume will be at the lower level when the unit is turned back on.

Mute

Press Mute to temporarily reduce volume by 20 dB. "MUTE" appears. Mute is terminated by pressing any button.

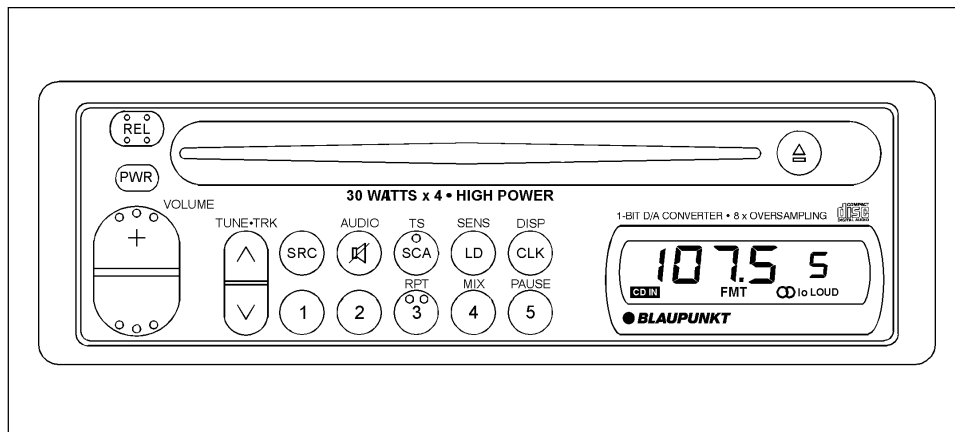

Bass, Treble, Balance and Fade

Press Mute/AUDIO for more than 1/2 second to access Bass. Subsequent presses access Treble, Balance and Fade modes.

Bass - Adjust from +7 to -7 at 2 dB/step using + to increase bass, - to decrease.

Treble - Adjust from +7 to -7 at 2 dB/step using + to increase treble, - to decrease.

Balance - Adjust balance from 9 (all the way left) using + to -9 (all the way right) using -.

Fader - Adjust fader from 9 (sound only from the front) using + to -9 (sound only from the rear) using -.

Loudness (LD)

Press LD to increase sound of low and high frequencies. LOUD icon appears. To cancel, press LD again.

Radio Operation

Last Station Memory

Each FM bank and AM band has its own last station memory, which holds last-tuned frequency for that band or bank irrespective of whether that frequency is stored into a preset.

Selecting Bands

Press SRC as needed to access FM1, FM2, FM3/FMT, AM/AMT banks.

Seek Tuning

Press ^ or v to seek next receivable frequency. Tuning stops at frequency that fulfills sensitivity requirements predetermined by sensitivity set through SENS/LD button.

Tuning Sensitivity (SENS)

Press SENS/LD for more than 2 seconds to switch between local (lo) and distant search sensitivity. When "lo" is absent from the display, search sensitivity setting is distant.

Radio Reception Hints

- When listening to weak or distant AM stations, adjusting the Treble to minimum (-7) will reduce noise and improve sound.
- In general, set SENS to distant tuning in rural areas or where stations tend to be weak and distant, and to local tuning when in metropolitan areas or areas where stations tend to be strong and local.

Stereo Symbol

Stereo symbol turns on if a stereo station with an incoming signal of at least 20 dB μ V is received. The unit gradually switches between mono to stereo automatically.

Manual Tuning

Press \wedge or \vee for more than 1/2 second and frequency will go one channel/step in direction pressed. Press and hold causes continuous manual tuning. Unit returns to seek tuning mode after 4 seconds or after storing a station on a preset.

Preset Station Storage

After tuning desired frequency on desired band, press and hold a Preset Button for more than 2 seconds to store current frequency. Audio is muted during storage, preset number appears, and beep acknowledges storage.

Preset Station Selection

Press desired Preset Button.

Travel Store

This feature allows you to automatically store stations onto all 5 preset buttons and is especially useful when traveling outside your normal listening area. In any FM Bank, press SCA/TS for 2 seconds to activate FM Travel Store. (In AM Bank, press it for 2 seconds to activate AM Travel Store.) TS appears. Beginning at the bottom of the band, TS stores five relatively strong stations, one on each of the five preset buttons, and returns to preset 1. Pressing any tuning-related button during Travel Store process cancels search operation.

Station Scan Tuning

Press SCA. Frequency blinks (along with preset number if appropriate) during scanning. Unit stops at receivable stations for 4 seconds. Unit continuously scans until user stops scan by pressing SCA, another tuning button or SRC.

Compact Disc Play Operation

CD Insertion

Make sure that "CD IN" isn't lit. Insert a disc into Disc Slot with printed surface facing up. Playback starts at beginning of first track. In rare instances when a disc has more than 28 tracks, it may take up to about a minute for the unit to read the disc and for playback to start.

CD Playback

When a CD is already in unit, press SRC as needed to activate CD play. Display shows elapsed play time and track number.

CD Eject

Press eject. Disc ejects. If disc is not removed within about 5 seconds (unless ignition off) or if eject is pressed again within this time, disc is automatically reloaded, although unit stays with current audio source. Press the SRC as required to access CD play and resume disc playback.

Insert/Eject Summary			
Activity	Ignition Off	Ignition On/ Unit Off	Ignition On/ Power On/ Other Source
Insert	No Reaction	Turns Unit On, becomes active source.	CD Player becomes active source.
Eject	Disc ejects. Stays out unless other button pressed.	Disc ejects. After 5 seconds, disc re-inserts.	Disc ejects. After 5 seconds, disc re-inserts.

Track Up/Down

Press \wedge and \vee select track. Elapsed play time and track number appear. Pressing \vee will restart current track if more than 1 second of track has been played. If less than 1 second, unit goes to beginning of previous track.

CD Track Cue and Review

Press and hold \wedge or \vee for audible cue or review.

CD Track Repeat Play

Press RPT to play current track repeatedly ("rpt" appears temporarily in display.) (This cancels MIX or SCAN if previously active.) If track manually advanced, RPT becomes active for new track. To cancel, press again.

Mix Play

Press MIX to randomly select a track and thereafter play tracks in random order ("rdm" appears temporarily in display.) (This cancels RPT or SCAN, if previously active.) A track will not be played a second time until all tracks have been played. To cancel, press again.

CD Track Scan

Press SCA to start Track Scan. SCA deactivates any active MIX or RPT modes. Track No. and Elapsed Play Time blink during scanning operation. Unit stops at each track for 10 seconds. Unit continuously scans until user stops scan by pressing SCA or another playback related button.

Pause

To pause, press $\parallel >$. To cancel, press again or press \wedge , \vee , SCA, RPT, or MIX.

CD Player Reset

In unlikely case of CD player trouble, reset CD player by turning unit's power and/or ignition off, and then power-on unit. (See TROUBLESHOOTING below.)

Auxiliary Input Jack

Connect other audio equipment, such as a portable cassette or DAT player, through the 500mV/3.5 mm pigtail connector. Access auxiliary equipment output by pressing SRC until "InP" appears. Adjust volume, bass, and treble settings through the receiver.

Troubleshooting Guide

The following check will assist in the correction of most problems which you may encounter with your unit. Before going through the check list below, refer back to the connection and operating procedures.

General

Trouble	Cause/Solution
No sound.	<ul style="list-style-type: none">Adjust the volume with the + button.With a two-speaker system set the fader control to the center position.

Radio reception

Trouble	Cause/Solution*
Preset stations are not receivable.	<ul style="list-style-type: none">The broadcast is too weak.
Automatic tuning is not possible.	<ul style="list-style-type: none">The broadcast is too weak. —> Use manual tuning.
Travel Store feature does not complete storing of six stations.	<ul style="list-style-type: none">Not enough broadcast frequencies are receivable.

* Also make sure that antenna is connected, extended and dry inside.

CD operation

Trouble	Cause/Solution
CD play does not start.	<ul style="list-style-type: none">Dusty or defective disc.The ambient temperature is more than 50°C (120°F).Disc has more than 28 tracks. Wait for about a minute for playback to start.The disc is inserted with the printed side downwards.CD-ROM (computer) disc inserted.
The sound skips due to vibration.	<ul style="list-style-type: none">The unit is installed at an angle of more than 20°.The unit is not installed on the sturdy part of a car.Dusty or defective disc.

If the above solutions do not help to improve the situation, consult your nearest Blaupunkt dealer or in the United States call 1-800-266-2528.



Bosch Group

**German Headquarters:
Blaupunkt-Werke GmbH
Postfach 77 77 77
D-31132 Hildesheim
Germany**

**Robert Bosch Corporation
Sales Group — Blaupunkt Division
2800 South 25th Avenue, Broadview, Illinois 60153
1-800-950-BLAU**

**Robert Bosch, SA., DE, C. V.
Dr. Lucio 270
Cols. Doctores, Mexico 06720**

**Made in Malaysia
Fabrique en Malasie
Hecho en Malasia
Fabricado en Malaysia**

Copyright 1997 by the Robert Bosch Corporation

**No portion of this work may be reproduced in any form without
the written consent of the Robert Bosch Corporation.**